



LCC Trading Co.,Ltd.



- ❑ Address: Okinawa Pref. (To be moved to Tokyo)
- ❑ Employees: 4
- ❑ Established in 2017
- ❑ Business Digital SOGO-SHOSHA
Export Japanese products/foods.
Overseas market development.

<http://lcct.co.jp/>

Outline of the demonstration project

- Trade DX for SMART Procurement of Japanese Food
POC of "Farm to Table" Eco-system

Cooperation with local companies/governments

- Local Partner : FROOD Tech(Marketplace)
Rida Global(Same-day Fulfillment AI Delivery)
- Detail of Part Partnership/Cooperation

SMART Procurement of Japanese Food.

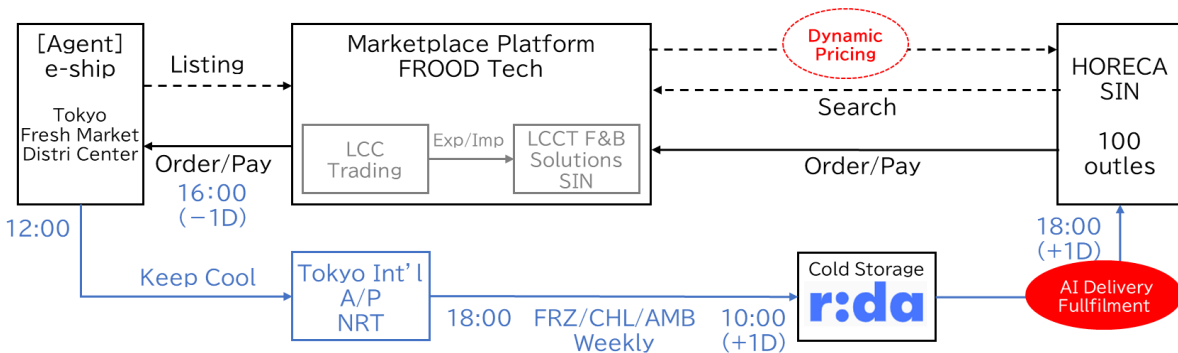

Targeted economic/social issues

- FOOD SECURITY is an urgent issue with less than 10% food self-sufficiency.
- One in twelve persons has visited Japan, Singapore people love Japanese food. But the delay in DX of trading from exporting countries to the waterfront causes the increase in the procurement cost and food loss of Japanese food

Details of demonstration

- By making Air-shipment a weekly scheduled service, delivery from Tokyo fresh market distribution center to 100 HORECAs will be completed within 30 hours.
- POC for "Farm to Table" Eco-system. Purchase orders from HORECAs are automatically forwarded to a procurement agency in Tokyo.
- Hypotheses testing for the introduction of dynamic pricing. Fluctuating the price according to FX and logistics cost to minimize procurement costs and food loss.

Expected outcome of beneficiary effects

- Trade DX reduces Japanese food procurement costs by 10% (Smart Procurement).
- Minimize food loss by shortening L/T and eliminating circulating inventory.
- After commercialization in Singapore, this Eco-system will be expanded to other ASEAN countries.
- This Eco-system will be re-imported as "reverse innovation" to Japan. It will lead to promotion of DX for exporting from ASEAN countries to Japan and expansion of exporting ASEAN products to JAPAN, the world's third largest market.