

# WALKCAR<sup>®</sup>

MTKSR-5

## USER MANUAL



COCOA MOTORS.

Read this user manual carefully prior to use.  
Keep this user manual for future reference.

# Table of Contents

|   |    |
|---|----|
| 1 WALKCAR®'s Features and User Restrictions     | 2  |
| 2 Safety Precautions                            | 2  |
| 3 Items Included in the Package                 | 4  |
| 4 Names of Parts                                | 4  |
| 5 Charging                                      | 5  |
| 6 Before Riding                                 | 6  |
| 7 Riding  | 8  |
| 8 Cleaning                                      | 14 |
| 9 Inspecting Front wheels (2 pieces)            | 14 |
| 10 Changing the Tires                           | 15 |
| 11 Storing                                      | 16 |
| 12 Disposing                                    | 16 |
| 13 Troubleshooting                              | 17 |
| 14 Questions and Answers                        | 18 |
| 15 LED Lighting Patterns                        | 19 |
| 16 Specifications of this Product               | 20 |
| 17 Warranty (Repair and Replacement)            | 21 |
| 18 Inquiry (Customer Desk)                      | 23 |
| 19 Certification                                | 23 |
| 20 Trademarks and Changes to the Specifications | 23 |

日本語

日本語

English

English

## 1 WALKCAR®' s Features and User Restrictions

WALKCAR® is designed to provide an alternative way of traveling to walking.

You can speed up, slow down, or turn as you go by shifting the center of gravity, without using a handle or a remote controller.

You can carry it around without having to worry about where to park it like a car or a bicycle.

WALKCAR® is designed for people aged 14 to 59, weighing 30 to 80 kg (\*), with a shoe size of 20 cm or larger, who are in a good physical and mental condition capable of maintaining the correct riding position. Anyone under the age of 16 must ride under the supervision of an adult.

Do not use this product if any of the following conditions apply.

- People who have medical conditions that put them at risk from strenuous exercise
- People who have problems with motor skills to maintain balance
- People under the influence of alcohol or drugs
- People during pregnancy

\* Weight including personal belongings.

## 2 Safety Precautions

To prevent harm to people, safety instructions are provided as follows.



### **WARNING**

This symbol indicates a hazard that could result in death or serious injury.



### **CAUTION**

This symbol indicates a hazard that could result in injury.

The following symbols explain the nature of the safety instructions.



This symbol indicates mandatory instructions.



This symbol indicates prohibitions.



## WARNING

### **There is a risk of death or serious injury.**

- Do not use this product for any purpose other than traveling, such as competition, amusement, racing or performance games.
- Do not use this product as a step.
- Do not charge, use, or leave this product in a place where the temperature is high, such as near a fire.
- Do not put stickers or paint on the riding board surface.
- Do not put this product into a fire or heat it.
- Do not put nails into this product or subject it to physical shocks.
- Do not disassemble or modify this product.

\* We shall not be held responsible for any injury or damage caused by failure to follow the instructions in this manual.

### 3 Items Included in the Package

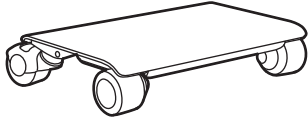

Main unit

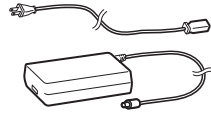

Charger and charging cable



USER MANUAL  
(this manual)

- \* In case any item is missing or damaged, contact the customer desk without using this product.
- \* Do not discard the packing box at the time of purchase. Save it for the storage of this product.

### 4 Names of Parts

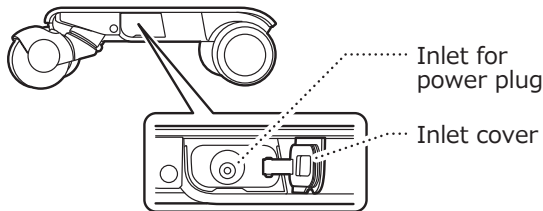
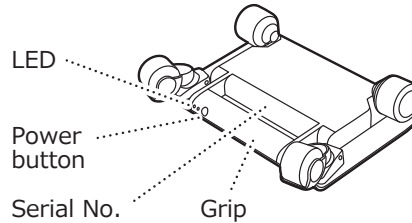
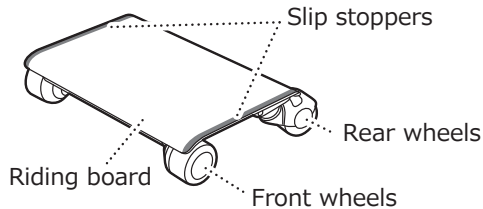

#### Meanings of product label symbols



Read USER  
MANUAL well  
and use correctly



Wear protection



No disassembly,  
destruction,  
modification

## 5 Charging

Follow the steps below to fully charge WALKCAR<sup>®</sup> before use.  
The LEDs on the main unit light up while charging and light off when fully charged.

### WARNING

**There is a risk of fire.**

- Use only the dedicated charger.
- Make sure that the charging cable and power plug are not damaged or broken.
- Keep the power plug is free of debris and dust.
- Use a power plug suited to the standard.
- When using a power strip, keep within the allowable range.
- Do not charge with a power supply that exceeds the specified voltage (240 V).
- Do not charge the battery during lightening.
- If you notice any abnormalities, such as unusual odors or smoke, stop charging and contact the customer desk.

### Charging procedure

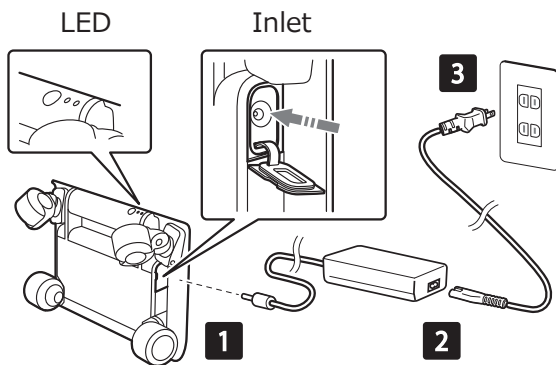

| Charge level | Main unit LEDs (Orange) |
|--------------|-------------------------|
| Under 50 %   | 2 OFF > 1 ON > 2 ON     |
| 50 % to 90 % | 1 ON + 1 FLASH          |
| 90 % to 95 % | 2 ON                    |
| 100 %        | 2 OFF                   |

## 6-1 Before Riding

### CAUTION

**There is a risk of injury.**

If there are any abnormalities with WALKCAR®, stop using it and contact the customer desk.

#### Check the following points before use.

- Front and rear wheels are not loose or rattling.
- Tires are not worn, peeled, cracked, or chipped.
- Inlet cover for the power plug is closed.
- There is no strange odor.
- No dirt has adhered to the riding board.

#### Holding/Carrying/Placing

Lift WALKCAR® by holding its grip.  
Let it cool down before you store it after use.  
Place it on a flat surface with the grip side up.

### CAUTION

**There is a risk of injury.**

- Hold it by the grip and do not let it drop.
- Carry it in a bag, etc. as much as possible.
- Do not touch around the front wheel until it has cooled down, as it becomes hot during use. Also, do not store it while it is hot.
- Do not leave this product on the floor or the road with the riding board facing upwards except when using it, as you may fall by accidentally placing your feet on it.

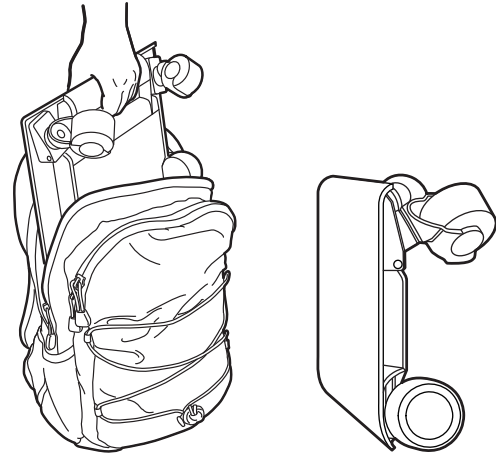

## 6-2 Before Riding

### Turning the power ON

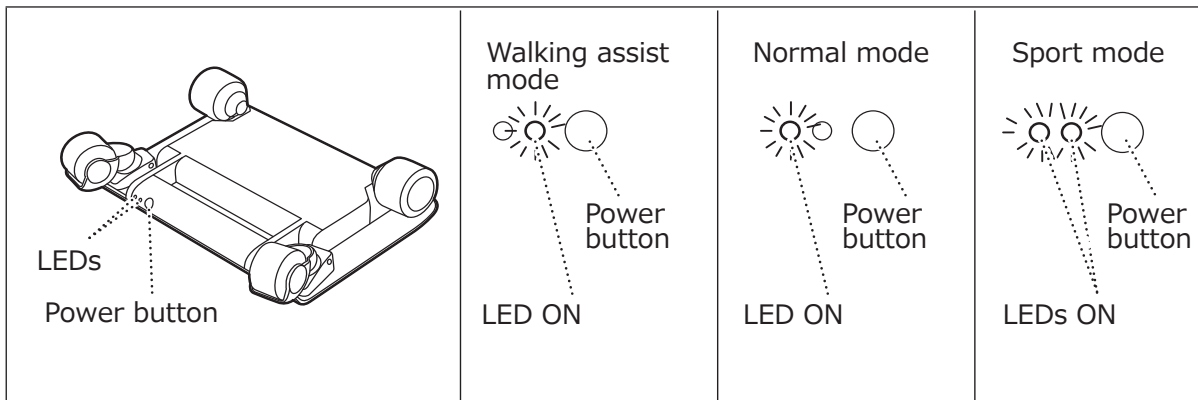

Press the power button to turn the power ON.

- Press the power button 1 time: Walking assist mode (max. 6 km/h)  
1 LED (Right side) lights ON.
- Press the power button 1 MORE time: Normal mode (max. 10 km/h)  
1 LED (Left side) lights ON.
- Press the power button 1 MORE time: Sport mode (max. 16 km/h)  
2 LEDs light ON.
- Press the power button 1 MORE time: Power OFF  
LEDs light OFF.

### Turning the power OFF

- Press the power button 1 time to turn the power OFF after use.



## 7-1 Riding



### WARNING

**There is a risk of death or serious injury.**

- Use only on dry, flat pavement (asphalt/tile/concrete).
  - When using at night, wear high-brightness clothing or safety clothing with reflective materials.
  - Use with the correct riding position and proper gear (see 7-3).
  - Use it for single-person use only.
  - Do not ride this product in the following situations.
    - While using an umbrella
    - While using a mobile phone or smartphone
    - While wearing headphones or earphones
    - Under the influence of alcohol or medication that affects your senses
    - While carrying a heavy load that affects your balance
    - In bad weather, such as rain, snow, and strong winds
    - When the road surface is wet or icy
    - When the road surface is hot
    - When the road is crowded or busy with traffic
    - While walking your pet
    - While going up or down the stairs
    - While going on a downhill
    - While wearing short pants or a skirt
    - While wearing long or loose accessories
    - When barefooted or wearing socks or stockings only
    - When wearing unsuitable footwear (see 7-2)
    - With the heels of your shoes crushed
    - When the soles of your shoes or riding board is wet
- Use per traffic regulations and local laws.
  - Follow instructions in “7-3 Correct riding position and proper gear” .
  - Always follow local law, regulation, and order when riding this product in public places.

## 7-2 Riding

### Suitable footwear for riding

- ! Use these types of shoes for safe riding.



Sneakers with flat soles

### Unsuitable footwear

- ⊘ Avoid these types of shoes for safe riding.



Business shoes, etc.



Shoes with curved or uneven soles



Sandals, etc.



High heels, boots, etc.

### Putting WALKCAR® in standby

#### ⚠ WARNING

**There is a risk of death or serious injury.**

- Do not ride when the riding board is wet.
- Do not ride with the riding board unlevel.

1. Turn the power ON.

Press the power button and check that the LED is lit. See "15 LED Lighting Patterns" for details.

2. Place WALKCAR® on a flat surface.
3. Check the following points.

- Riding board is level.
  - If the riding board is not level, push it forward and turn the rear wheels to the back, and restore the level position.

Rear wheel

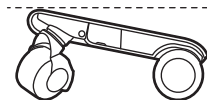

⊘ NOT rideable

Rear wheel

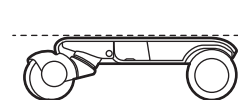

! Rideable

- No liquid or dirt has adhered to the riding board
- Inlet cover for the power plug is closed

## 7-3 Riding

### Correct riding position and proper gear

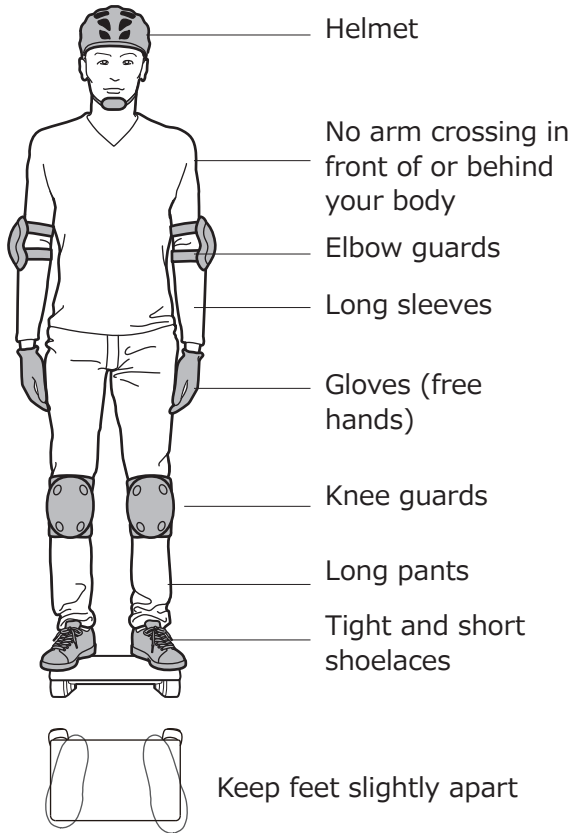

### Hazardous ways of riding

**⚠ WARNING**

**There is a risk of death or serious injury.**

⊘ Do not ride as shown below.

Diagrams illustrating hazardous ways of riding:

- Feet together
- On one leg
- Backward
- Sideway
- Squat or sit
- Jump onto or jump on

## 7-4 Riding

Practice riding as follows until you can control WALKCAR<sup>®</sup> without losing balance.

- Ride in Walking assist mode or Normal mode until you feel comfortable.
- Practice riding in a low-traffic, wide and safe area (maintained and flat road).

### Sensors in WALKCAR<sup>®</sup>

WALKCAR<sup>®</sup> senses weight by 4 built-in sensors (see the figure) to make movements.

#### Starting

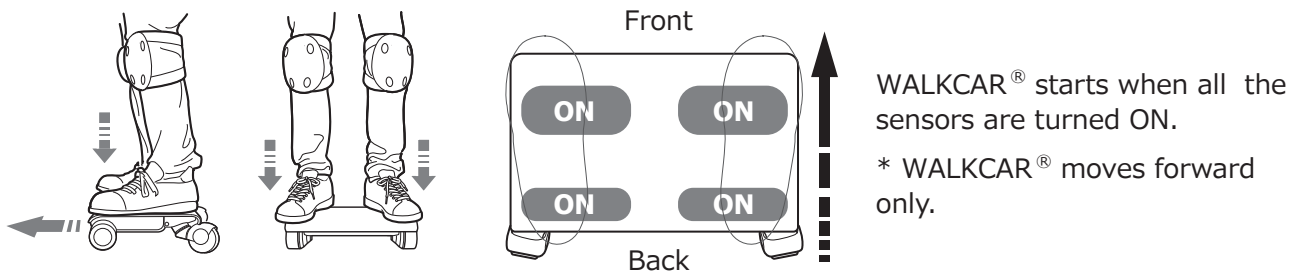

#### Stopping

- Normal stopping  
Keep slowing down until it stops (turn off either sensor on the front).  
\* See "Slowing down" on the next page.
- Emergency stopping  
Get off WALKCAR<sup>®</sup>. It stops immediately when all the sensors are turned off.

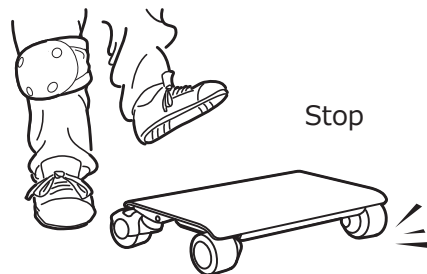

# 7-5 Riding

## Speeding up

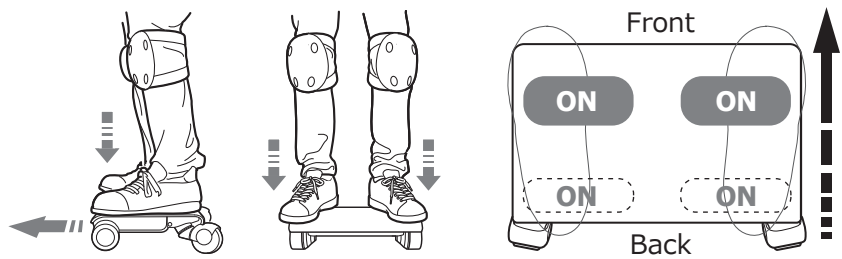

Speed increases when 2 sensors on the front are turned ON.

You can keep increasing speed up to 6 km/h (in Walking assist mode), 10 km/h (in Normal mode) or 16 km/h (in Sport mode).

## Slowing down

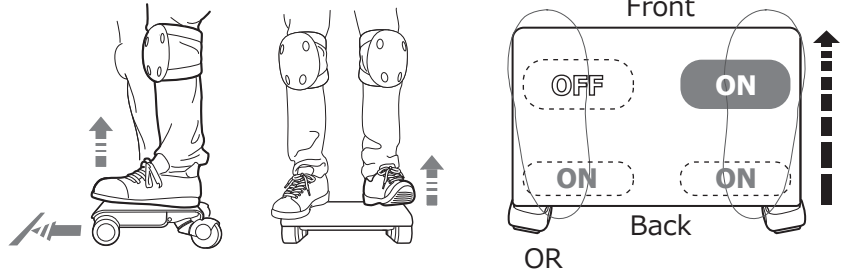

Speed decreases when you raise your either toe, turning off the corresponding sensor.

If you keep decreasing speed, it keeps dropping until a complete stop.

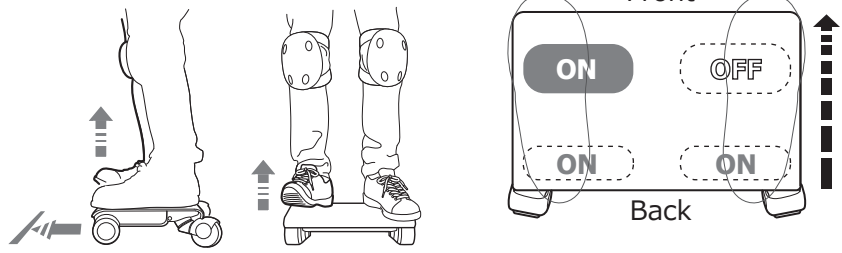

You can raise either your left or right toe to slow down in the same way.

## 7-6 Riding

### Turning

While moving forward, shift your weight on either leg to turn in that direction. Keep your balance as WALKCAR<sup>®</sup> turns.



Shift your weight to the left or right to turn.

Twist your upper body in the turning direction.

Slightly bend your knee in the turning direction.

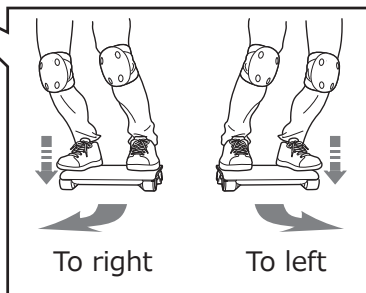

If you feel unusual vibration (rattling), difficulty in turning, or abnormal noises, check the tires.

### Controlling speed while moving forward

Adjust speed by speeding up and slowing down, by turning on and off the sensors on the front.

Front



You can keep constant speed or make slight adjustments by speeding up and slowing down repeatedly.

### When not riding (stopped)

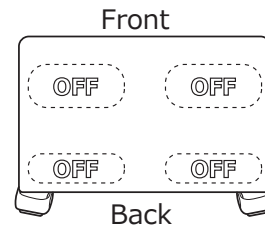
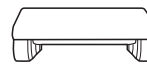
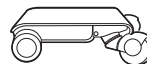

## 8 Cleaning

### CAUTION

**There is a risk of electric shock.**

Do not immerse this product in water. There is a risk of electric shock.

 When WALKCAR<sup>®</sup> has become dirty, follow the procedure below to clean it.

1. Remove dirt around the tires using a toothbrush or the like.
2. Wipe off dirt on WALKCAR<sup>®</sup> using a damp soft cloth.
3. Dry WALKCAR<sup>®</sup> using a soft cloth.
  - \* Leather material is used for the handle part. Use a leather cleaner to clean the handle part.

 Do not clean in any of the following ways.

- Cleaning with alcohol, gasoline, acetone or other corrosive or volatile solvents
- Cleaning with a pressure washer or pressure hose

## 9 Inspecting

Inspect WALKCAR<sup>®</sup> as described below.

- Before each use and the first use after storage
  - Tires are not worn, peeled, cracked, or chipped.
  - The main unit does not tilt abnormally when it is placed on a level surface.
  - There is no strange odor.
  - No dirt has adhered to the riding board.

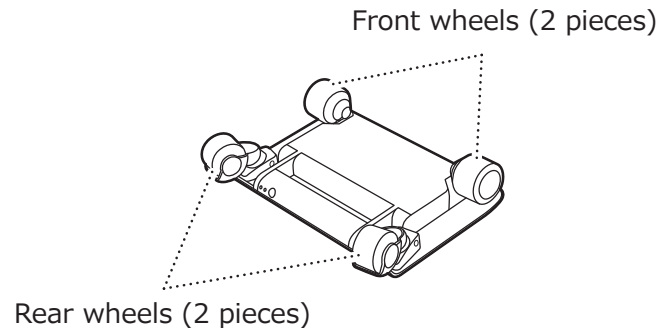

## 10 Changing the Tires

Tires are a consumable item. If the tires show excessive wear, peeling, cracking, chipping, or bulging as shown below, or if there is any unusual noise or rattling while riding, stop using this product and replace the tires. Be sure to use genuine tires. For details, contact the customer desk.

[Front wheels]

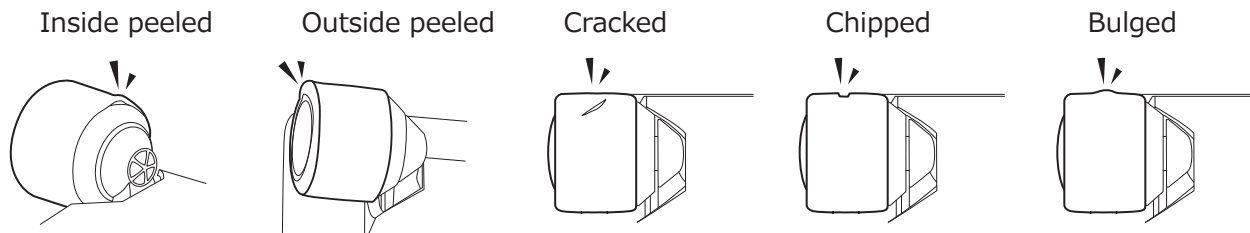

[Rear wheels] WALKCAR<sup>®</sup>'s rear tires wear more on the inside as it travels. However, this is due to the characteristics of the product and does not indicate a problem. If you feel difficulty or staggering when making turns, or unstableness while riding, replace the tires.

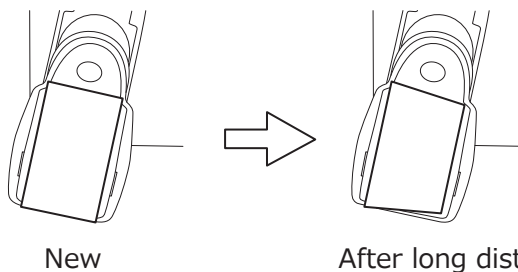



## 11 Storing

When WALKCAR<sup>®</sup> will not be used for an extended period of time, store it as below.

1. Turn the power OFF.
2. Close the inlet cover for the power plug.
3. Store it in the original packing box.

### ! Appropriate condition for storing

- Indoors at a temperature range of 1 to 30 °C
- Where humidity is low
- Where there is little dust

### ⊘ Inappropriate condition for storing

- Outdoors or where there is much dust
- Where there is direct sunlight
- Inside a vehicle
- Where humidity is high or condensation is likely
- Where there is potential for flooding
- Where temperature is too high or too low

## 12 Disposing

### CAUTION

**There is a risk of electric shock.**

Do not disassemble this product. There is a risk of electric shock.

This product is equipped with a lithium-ion battery. When disposing of this product, follow the local government's collection methods.

## 13 Troubleshooting

If the problem persists, contact the customer desk.

| Problem  | Possible cause  | Action   |
|--|---|--|
| The main unit LEDs do not light ON even when the power button is pressed.  | The battery may not be fully charged.                           | See "5 Charging" and charge the battery. Alternatively, press and hold the power button and turn it OFF forcibly.  |
| The travel distance on a full charge has become extremely short.           | The battery may have deteriorated.                              | To replace the battery (for a fee), contact the customer desk.   |
| Riding is unstable, or an unusual noise is heard.                          | The tires may be worn or damaged.                               | To replace the tires (for a fee), contact the customer desk.   |
| A strange odor or smoke is generated from the main unit.                   | A failure may have occurred with the electrical component.      | Stop using this product and contact the customer desk.   |
| The front wheels do not stop, or the power cannot be turned OFF.           | The drive system may have an error or failure.                  | Press and hold the power button and turn it OFF forcibly. If the front wheels still do not stop, wait until they stop turning and contact the customer desk. |
| It does not start when ridden even when the battery is adequately charged. | Riding position may be incorrect (not detected by the sensors). | See "7 Riding" and ride correctly.   |

| Problem  | Possible cause  | Action   |
|--|---|--|
| The main unit LEDs flash in blue while failing to work.    | An internal error may have occurred for some unspecified reason.            | If the LEDs do not light OFF after some time, contact the customer desk.   |
| The main unit has become hot.                              | The heat is from the motor and battery, and it does not indicate a failure. | Wait until it cools down before using it again.  |
| The LED on the charger flashes in red and will not charge. | Charging has been stopped by a protection function.                         | Disconnect the charger from the outlet and connect it again. If the problem persists, contact the customer desk. |

## 14 Questions and Answers

|  |  |
|--|--|
| Can I move backward?                                   | WALKCAR <sup>®</sup> moves forward only. |
| How do I get an additional charger and charging cable? | Contact the customer desk.               |
| How do I replace the worn wheels (front and rear)?     | Contact the customer desk.               |



























For other questions and answers, refer to our website (<https://www.cocoamotors.com>).  
If the problem persists, contact the customer desk ([support@cocoamotors.com](mailto:support@cocoamotors.com)).

## 15 LED Lighting Patterns

The LEDs light ON, flash, or light OFF to indicate the status of WALKCAR<sup>®</sup> as follows.

Power button LEDs



| Color  | LED   | Mode                | Status              |  |
|--------|---|---------------------|---------------------|--|
| (OFF)  |    | OFF                 | Riding              | Normal                                     |
|        |    |                     | Charging            | Normal Charge level is 100 %               |
| Green  |   | ON (1 LED) left     | Walking assist mode | Normal Charge level is 50 % or more        |
|        |   | ON (1 LED) right    | Normal mode         | Normal Charge level is 50 % or more        |
|        |   | ON (2 LEDs)         | Sport mode          | Normal Charge level is 50 % or more        |
| Orange |   | ON (1 LED) left     | Walking assist mode | Normal Charge level is under 50 %          |
|        |   | ON (1 LED) right    | Normal mode         | Normal Charge level is under 50 %          |
|        |   | ON (2 LEDs)         | Sport mode          | Normal Charge level is under 50 %          |
|        |   |                     | Charging            | Normal Charge level is 90 % to under 100 % |
|        |   | FLASH (1 LED) left  | Walking assist mode | Normal Charge level is 0 %                 |
|        |   | FLASH (1 LED) right | Normal mode         | Normal Charge level is 0 %                 |
|        |   | FLASH (2 LEDs)      | Sport mode          | Normal Charge level is 0 %                 |
|        | Repeat "OFF > 1 ON > 2 ON"  |                     | Charging            | Normal Charge level is under 50 %          |
|        |   | ON+FLASH            | Charging            | Normal Charge level is 50 % to under 90 %  |
| Blue   |   | FLASH (2 LEDs)      | Error               | Abnormal Contact the customer desk         |

## 16 Specifications of this Product

### Basic specifications

|                                       |   |
|---------------------------------------|---|
| Product Name                          | WALKCAR®  |
| Model                                 | MTKSR-5   |
| Max. Load Capacity                    | 80 kg   |
| Min. Load Capacity                    | 30 kg   |
| Max. Speed                            | 16 km/h (Sport mode)<br>10 km/h (Normal mode)<br>6 km/h (Walking assist mode) |
| Max. Output                           | 600 W   |
| Rated Output                          | 260 W   |
| Energy (Rechargeable Battery)         | Lithium ion (Li-ion), 68 Wh   |
| Full Charge Time                      | 60 minutes  |
| Travel Distance on Full Charge        | 7 km (Walking assist mode)<br>7 km (Normal mode)<br>5 km (Sport mode)         |
| * 60 kg load, in our test environment |   |
| Required Power                        | 100 to 240 V, 50/60 Hz  |

|                                       |                         |
|---------------------------------------|-------------------------|
| Dimensions (length, width, height)    | 215 mm x 346 mm x 74 mm |
| Weight                                | 2.9 kg                  |
| Operating Environment                 | -10 ~ 40 °C             |
| Max. Climbing Capacity                | 10 degrees              |
| * 60 kg load, in our test environment |                         |

The above figures are subject to change due to factors such as the operating environment.

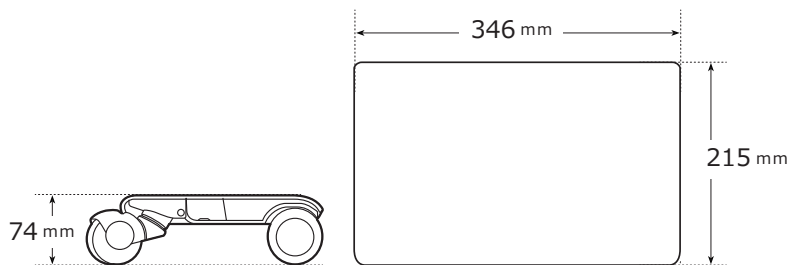

## 17 Warranty (Repair and Replacement)

We have taken all possible precautions to ensure the quality of this product. However, if a defect occurs while using the product per contents of the USER MANUAL during the warranty period (3 months from the date of shipment), the product will be repaired or replaced free of charge. There may be scratches or stains on the outer box or packing material during delivery. In rare cases such as these, we may not handle it as a defective product unless it affects the main unit and accessories.

Note that the customer will be responsible for any repair costs (repairing and shipping) after the warranty period has expired. To request a repair or replacement, contact the customer desk (support@cocoamotors.com).

\* Note that the following cases are not covered by the warranty, even within the warranty period.

- Damages on the exterior of the main unit that occurred after opening the package
- Failures due to modification by the customer
- In the absence of a serial number or an image of the product in question
- Failures or damages caused by usage contrary to the contents of the USER MANUAL
- Failures or damages due to natural disasters such as fire, wind and water damage, lightning, earthquake, tsunami, or eruption
- Failures or damages due to excessive impact from falling, slipping, or collision or the like while riding
- Failures or damages due to improper handling during transportation or travel by the customer
- Wear and damage of consumables (tires) and deterioration of the battery
- Failures or damages due to natural wear and tear, rust, mildew, humidification, rot, deterioration, discoloration, or other similar reasons
- Failures or damages due to external factors such as dropping or wetting of the product
- If the condition of the product cannot be confirmed due to the absence of the product for reasons such as theft, loss, or misplacement

\* This product may correspond to a hazardous material for air transportation. Due to local laws and regulations, the repaired product may become difficult to deliver or may have to be shipped by sea.

## **18 Inquiry (Customer Desk)**

Email address: [support@cocoamotors.com](mailto:support@cocoamotors.com)

## **19 Certification**

For details of the certification that this product has obtained, refer to our website:  
<https://www.cocoamotors.com>

## **20 Trademarks and Changes to the Specifications**

WALKCAR<sup>®</sup>, cocoa motors., and the logo (⊗) are trademarks of cocoa motors.Inc.  
The trademarks of other companies described in this document are the property of their respective companies. cocoa motors.Inc. does not claim any rights in the trademarks of other companies.  
Some of the features described in this document may not apply to your product.  
cocoa motors.Inc. reserves the right to change the specifications of this product and the contents of USER MANUAL.





COCOA MOTORS.